

<b>Classification:</b>	SCOUY	SCOUT	SCOUT
<b>Class:</b>	3	3	3
<b>Model:</b>	I	II	III
<b>Class Commission Date:</b>	2248	2252	2256
<b>Number Proposed:</b>	30	38	50
<b>Constructed:</b>	30	38	1
<b>Lost:</b>	1	3	
<b>Destroyed:</b>	11	15	
<b>Scrapped:</b>	1	3	
<b>Training:</b>			
<b>Captured:</b>			
<b>Sold:</b>			
<b>Superstructure:</b>	20	20	21
<b>Damage Chart:</b>	C	C	C
<b>Dimensions:</b>			
Length:	32 m	32 m	32m
Width:	25 m	25 m	25m
Height:	13 m	13 m	13m
<b>Displacement:</b>	39495 mt	39495 mt	38575 mt
<b>Cargo Specs</b>			
Total SCU:	21 SCU	21 SCU	18 SCU
Cargo Capacity:	1040 mt	1040 mt	900 mt
<b>Computer Type:</b>	L14	L14	L14
<b>Landing Capacity:</b>	N	N	N
<b>Cloaking Device:</b>			
Power to Engage:			
<b>Transporters:</b>			
3-person:	1	1	1
20-person Combat:			
22-person Emergency:			
cargo:	1	1	1
<b>Laboratories:</b>			
<b>Brigs:</b>	4	4	4
<b>Replicators:</b>			
<b>Shuttlecraft:</b>			
Light Shuttle:			
Standard Shuttle:			
Heavy Shuttle:			
Cargo Shuttle:			
Medical Shuttle:			
Combat Shuttle:			
<b>Ships Complement:</b>	32	32	30
Officers:	4	4	4
Enlisted:	17	17	16
Troops:	10	10	10
Passengers:	5	5	5
<b>ENGINEERING-</b>			
<b>Total Power Available:</b>	15	19	19
<b>Movement Point Ratio:</b>	1/1	1/1	1/1
<b>Warp Engine Type:</b>	FWA-1	FWA-2	FWA-2
Number:	2	2	2
Power Units:	6	8	8
Stress Chart:	J/M	J/M	J/M
Optimum Speed:	4.55	4.55	4.6
Max Safe Cruising:	7.00	7.00	7
Emergency Speed:	9.00	9.00	9.00
Maximum Speed:			
<b>Impulse Engine Type:</b>	FIA-3	FIA-3	FIA-3
Power Units:	3	3	3
<b>WEAPONS/DEFENSE</b>			
<b>Beam Weapon:</b>	FL-5	FL-5	FH-1
Firing Arcs:	2F	2F	2F
Firing Chart:	H	H	F
Maximum Power:	2	2	2
Damage Modifiers			
+3			
+2	5-7	5-7	
+1	1-4	1-4	
<b>Beam Weapon:</b>			
Firing Arcs:			
Firing Chart:			
Maximum Power:			
Damage Modifiers			
+3			
+2			
+1			
<b>Torpedo Type:</b>	FAC-3	FAC-3	FP-1
Firing Arcs:	2F	2F	2F
Firing Chart:	H	H	L
Power To Arm:	4	4	1
Damage:	10	10	10
Stock:	40	40	40

<b>Shields-</b>			
<b>Shield Type:</b>	FSD	FSD	FSD
<b>Shield Point Ratio:</b>	1/2	1/2	1/2
<b>Maximum Shield:</b>	10	10	10
<b>Combat Efficiency</b>	8.5	9.7	9.6
<b>D-</b>	84.6	96.6	98.0
<b>WDF-</b>	10.0	10.0	9.8

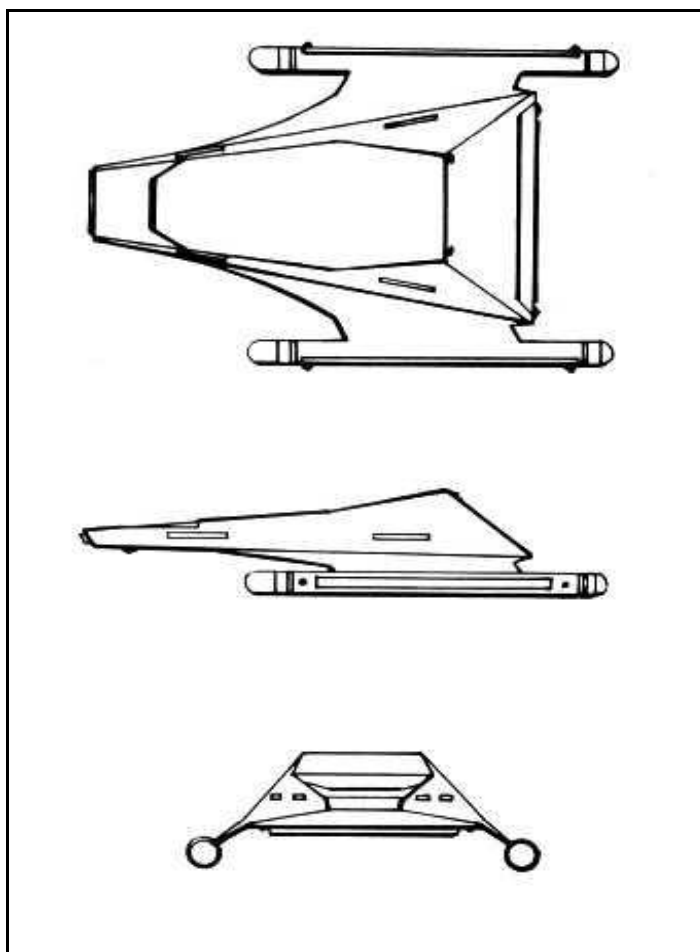

The Mission-X was ordered by Starfleet Intelligence Command in 2248. Externally identical to the standard Mission Class scout/courier, the Mission-X had a combat capability greater than many destroyers and cruisers. The major drawback of the design was the high cost of fitting such components into a small hull. Additionally the design compromised the crew facilities and fuel storage, making missions of more than seven days duration impossible.

Prior to the Four Years war the ships were primarily used in Intelligence gathering duties along the border away from the glare of publicity. But war changed that, as some of these ships were stationed at what became known as 'Malta Station' which was besieged by Klingon Forces for much of the war. The ships assigned to that station earned Federation wide fame for their brave actions supporting the defence of the station. These four ships 'Faith', 'Hope', 'Charity' and 'Desperation' collectively destroyed 34 Klingon Vessels, and crippled a further 46. Starfleet refuses to confirm whether the original four ships survived the war, or whether they were secretly replaced during the war after being destroyed.

30 Mark 1 ships were built, and 20 new build Mark 2s. The 18 Surviving Mark 1 vessels were uprated to Mark 2 standards, the only difference being the FWA-2 engine installation. 2256 saw the testing of an enhanced Phaser and Photon Torpedo armed Mark 3 version. This ship was marginally less combat effective than the Mark 2 and more expensive to build. Only the prototype vessel was built of this mark as it was clear that the earlier ships were still highly effective. The Mission-X class was finally withdrawn from service in the 2280's, it was the last FL/FAC Armed ship on the active service list. Rumours do persist though of special variants still serving with Intelligence command, but these cannot be substantiated.

The Mission Class Design and History are © FASA  
 Image c/o www.shipschematics.net  
 Revised Mission Class Statistics and History by Lee Wood, Mis V1.0  
<http://homepage.nflworld.com/steven.bacon/>  
 Star Trek is © Paramount Pictures, No infringement intended  
 Star Trek Starship Tactical Combat Simulator is © FASA, No infringement intended